

60Hz/1800 r.p.m-P.F.0.8					Prime Power	Standby Power	Rated Current
Genset	Engine	Alternator	Voltage (V)	PH	kW/kVA	kW/kVA	Amps
FC112X-P	1104C-44TAG2	LSA 44.2 L12 UCI274G TPA274S6	240 (220-240)	1	90/112	100/125	466.7
		LSA44.3M6 UCI274C TPA274VS2	380/220	3	90/112	100/125	170.9
		LSA44.3M6 UCI274C TPA274VS1	208/120	3	90/112	100/125	312.3
		LSA44.3S5 UCI274C TPA224VL7	220/127	3	90/112	100/125	295.2
		LSA44.3S5 UCI274C TPA224VL7	230/132	3	90/112	100/125	282.4
		LSA44.3S4 UCI274C TPA224VL7	480/277	3	90/112	100/125	135.3

**Ratings:** All three Phase generator sets are rated at 0.8 power factor. All single-phase generator sets are rated at 0.8 or 1.0 power factor. POWERGEN reserves the right to change the design or specifications without notice and without any obligation or liability whatsoever.

**Prime Power:**

Available continuously at variable load in lieu of commercially purchased power for an unlimited number of hours per year in accordance with ISO8528-1, and an overload of 10% permitted for one hour in every twelve hours of operation in accordance with ISO 3046-1.

**Standby Power:**

Emergency Standby Power in variable load applications in accordance with ISO8528-1 in the event of a utility power failure. No overload available for this service as relevant alternators are peak continuous rated at 27°C.

**Overall Dimensions (mm) & Weight (kg)**

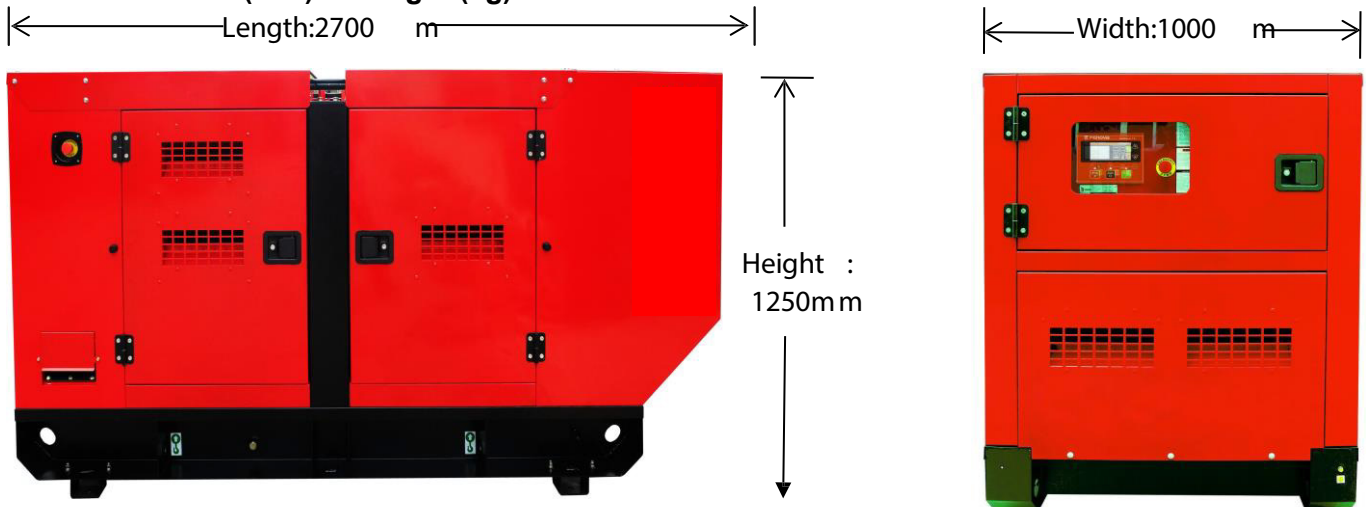

**Weight (kg): 1400**

## Standard and Optional Accessories

System	Standard ●	Optional ○
<b>Air Intake System</b>	<ul style="list-style-type: none"> <li>● Standard air filter</li> <li>● Air filter overload alarm</li> </ul>	<ul style="list-style-type: none"> <li>○ Air prefilter</li> <li>○ Heavy air filter</li> </ul>
<b>Cooling System</b>	<ul style="list-style-type: none"> <li>● 50°C radiator</li> <li>● Low water level alarm ①</li> <li>● Fan and belt guard</li> <li>● Discharge valve</li> </ul>	<ul style="list-style-type: none"> <li>○ Antifreeze</li> <li>○ Water jacket heater</li> </ul>
<b>Exhaust System</b>	<ul style="list-style-type: none"> <li>● Stainless steel bellow</li> <li>● Residential silencer</li> <li>● Complete exhaust pipe</li> <li>● Rain cap</li> </ul>	<ul style="list-style-type: none"> <li>○ Stainless steel silencer</li> <li>○ Stainless steel exhaust pipe</li> </ul>
<b>Fuel System</b>	<ul style="list-style-type: none"> <li>● 8 Hours integrated base fuel tank</li> <li>● Standard fuel filter</li> <li>● Fuel level gauge</li> <li>● Fuel filling cap</li> <li>● Fuel hose</li> </ul>	<ul style="list-style-type: none"> <li>○ 6 Hours double wall base fuel tank</li> <li>○ Fuel-water separator</li> <li>○ Oil level sensor ② ③</li> <li>○ Automatic fuel top up system ②</li> </ul>
<b>Lubrication System</b>	<ul style="list-style-type: none"> <li>● Standard oil filter</li> <li>● Manual oil pump and drain</li> </ul>	<ul style="list-style-type: none"> <li>○ Oil heater</li> <li>○ Lube oil level indicator</li> <li>○ Oil temperature indicator ②</li> </ul>
<b>Alternator and Electric Switch</b>	<ul style="list-style-type: none"> <li>● Shunt or self excited</li> <li>● Class H insulation</li> <li>● H class temperature rise</li> <li>● DELIXI MCCB</li> <li>● Terminal connection lugs (L1, L2, L3, LN)</li> </ul>	<ul style="list-style-type: none"> <li>○ PMG or AREP (Leroy-somer only)</li> <li>○ Alternator space heaters</li> <li>○ PT100 winding temperature sensors</li> <li>○ Weaver AVR</li> <li>○ Weaver prolapse transformer</li> <li>○ F class temperature rise</li> <li>○ 4 Pole circuit breaker with leakage protection</li> <li>○ Circuit breaker - 4 pole</li> <li>○ ABB MCCB</li> <li>○ MCCB auxiliary contact and shunt tripping device</li> </ul>
<b>Control System</b>	<ul style="list-style-type: none"> <li>● Intelligent 1.0 for 4 cylinders engine</li> <li>● Intelligent 3.0 for 6 cylinders engine</li> <li>● Intelligent 5.0 for ECU engine</li> </ul>	<ul style="list-style-type: none"> <li>○ Panel lighting</li> </ul>
<b>Silent / Base</b>	<ul style="list-style-type: none"> <li>● 67-72 db(A) @ 3 meters</li> <li>● 4mm -6mm Steel base</li> <li>● Transportation support leg</li> <li>● Single hook</li> <li>● Power coating enclosure</li> <li>● Anti-vibration mounting between engine /alternator and baseframe</li> <li>● Emergency stop mounted outside the canopy</li> <li>● Standard color: Ral 3020</li> </ul>	<ul style="list-style-type: none"> <li>○ Forklift holes</li> <li>○ Enclosure color:</li> <li>○ Trailer for off road or on road</li> </ul>
<b>Start / Charge</b>	<ul style="list-style-type: none"> <li>● Battery with bracket and cables</li> <li>● Engine battery charger</li> <li>● 3A Mains charger</li> </ul>	<ul style="list-style-type: none"> <li>Low temperature starting batteries</li> <li>Battery switch</li> <li>High current charger (10A - 20A)</li> </ul>

**Remark:**

- ① Not available for Perkins 400 series engines
- ② When you need the automatic oil top up system, you have to use the electrical oil level sensor.
- ③ You can choose either electrical oil level sensor or oil temperature sensor.

## Engine

Engine specifications		Lubrication system	
Manufacture	Perkins	Total Lubrication system capacity	8.0 Litres
Engine model	1104C-44TAG2	Minimum sump capacity	5.5 Litres
Engine type	4 stroke, Vertical in-line, 4-cylinder	Maximum sump capacity	7.0 Litres
Engine speed	1800 r.p.m	Max continuous oil temperature	125°C
Prime power	102 kW	Fuel system	
Standby power	112 kW	Type of injection	Direct injection
Governor type	Electronic	Fuel lift pump-flow/hour	120 - 150 Litres/hour
Air intake way	Turbocharged, air-to-air charge cooled	Fuel consumption at 100% standby power	29.7 Litres/hour
Displacement	4.4 L	Fuel consumption at 100% prime power	26.9 Litres/hour
Cylinder bore * stroke	105mm x 127mm	Fuel consumption at 75% prime power	20.2 Litres/hour
NO. of cylinders	4	Fuel consumption at 50% prime power	14.1 Litres/hour
Compression ratio	18.23:1	Fuel tank capacity	8-12 hours
Brake mean effective pressure	1618-1780kPa	Cooling system	
Mean piston speed	7.62 m/s	Total system capacity	
Combustion air flow	7.8 m <sup>3</sup> /min	- With radiator	12.6 Litres
Engine coolant flow	170 Litres/min	- Without radiator	7.0 Litres
Exhaust system		Thermostat operation range	82-93 °C
Exhaust gas flow	20.4 m <sup>3</sup> /min	Maximum top tank temperature	110°C
Exhaust gas temperature	517-574°C	Electric system	
Maximum back pressure	15 kPa	Electrical system voltage	12 V
Exhaust outlet size	64 mm	Battery	Maintenance-free
Air intake system		Connecting cables	Available
Maximum air intake restriction		Energy balance	
- Clean filter	5 kPa	Energy to coolant and lubricating oil	57.7-64 kW
- Dirty filter	8 kPa	Energy to exhaust	89.8-99.7 kW
- Air filter type	2 Stage Cyclonic/Paper Element	Energy to radiation	8.5-9.4kW

## Alternator

60Hz/1800R.P.M

General data		Insulation class	
Power factor	Cos $\phi$ = 0.8	Bearing	Single
Excitation	Shunt / Brushless	Altitude	≤ 1000 m

## Ratings

Brand	Alternator	Number of wires	AVR Model	PH	Voltage (V)	Prime Power	Standby Power
						kW/kVA	kW/kVA
Leroy-somer	LSA 44.2 L12	12	R250	1	240 (220-240)	88/110	98/123
Stamford	UCI274G		AS440			98.7/123.4	N/A
Tide	TPA274S6		SX460			92/115	100/125
Leroy-somer	LSA44.3M6	12	R250	3	380/220	99/124	109/136
Stamford	UCI274C		AS440			96/120	105.6/132
Tide	TPA274VS2		SX460			100/125	110/137.5
Leroy-somer	LSA44.3M6	12	R250	3	208/120	108/135	119/149
Stamford	UCI274C		AS440			90/112.5	96/120
Tide	TPA274VS1		SX460			90/113	97/121
Leroy-somer	LSA44.3S5	12	R250	3	220/127	92/115	101/126
Stamford	UCI274C		AS440			94/117.5	102/127.5
Tide	TPA224VL7		SX460			89/111	95/119
Leroy-somer	LSA44.3S5	12	R250	3	230/132	92/115	101/126
Stamford	UCI274C		AS440			94/117.5	102/127.5
Tide	TPA224VL7		SX460			89/111	95/119
Leroy-somer	LSA44.3S4	12	R250	3	480/277	90/113	99/124
Stamford	UCI274C		AS440			100/125	110/137.5
Tide	TPA224VL7		SX460			94/117.5	101/126



Intelligent

Intelligent

Intelligent

1.0

3.0

5.0

Viewable parameters	Phase voltage	3	3	3
	Wire voltage	3	3	3
	Current	Instrument	3	3
	Frequency	●	●	●
	Active power	×	●	●
	Reactive power	×	●	●
	Apparent power	×	●	●
	Power factor	×	●	●
	Electric energy metering	×	×	●
Generator protection	Abnormal voltage	●	●	●
	Over-current warning	×	●	●
	Over current protection	×	●	●
	Over Frequency protection	●	●	●
	Short circuit protection	MCCB	MCCB+○	MCCB+○
Engine figure	Oil pressure	●	●	●
	Water temperature	●	●	●
	Fuel level	○	○	○
	Speed	●	●	●
	Battery voltage	●	●	●
	Elapsed time	●	●	●
Engine protection	Low oil pressure warning	●	●	●
	Low oil pressure protection	●	●	●
	High temperature warning	●	●	●
	High temperature protection	●	●	●
	Overspeed warning	●	●	●
	Overspeed protection	●	●	●
	Charge fault	●	●	●
Function	Remote start-stop	●	●	●
	AMF	●	●	●
	Programmable input	3	7	7
	Programmable output	6	7	7
	Port extension	USB	○	○
	Remote monitoring	×	○	○
	Communication port	×	○	○
	CAN	●	○	●
	Start/Stop time control	×	×	●
	Maintenance tips	×	×	●
	Fault record	×	×	●
	Multi-language function	×	●	●

Remark: ● Standard

○ Optional

× NA

## Automatic Transfer Switch

### (Safety Installation: Detect - Control – Switch System)

POWERGEN offers not only a changeover switch but also an integrated mains detection and switch system for your 24 Hour Power Protection. The system enables automatic start-up and operation of the generating set in the event of a mains power failure, overvoltage or loss of phase; and also mains automatic re-transfer once it come back.

The system has a wide application such as hospital, bank, telecom, airport, broadcasting station and hotels.

#### System Advantages

- Automatically transfer and re-transfer load from main power to gen-power without operator intervention operation. (Both automatic and manual)
- ATS Controller (AMF function), seamless integration with Intelligent 5.0
- Available from 32 – 3200A, better protection for 4 pole switch.
- Available in standard, bypass isolation and service-entrance configurations.
- Configurable in open, closed and programmed transition operating modes.
- Designed to interface seamlessly with POWERGEN generators and switchgear.
- Drip Proof IP23 Enclosure.
- Easy Installation: Wall-mounted & Floor standing
- Comes fully loaded with the technology to do the job.



Rated Current	Breaker Type			
	A	Chinese	ABB	Socomec
32	x		B	x
63	A		B	B
80	x		x	B
100	A		B	B
125	x		B	B
160	B		B	B
200	x		B	x
250	C		B	B
300	x		x	x
315	x		C	x
400	C		C	C
630	C		D	D
800	D		D	D
1000	D		D	D
1250	D		D	D
1600	D		D	E
2000	E		E	E
2500	E		E	E
3200	E		x	E

#### Dimensions : mm

A: 400x200x500

B: 500x300x650

C: 600x400x1200

D: 800x600x1400

E: 1000x800x1600



## **Controller**

### **StandardParameters**

- Gen phase voltage
- Generator frequency
- Engine speed
- Battery voltage
- Engine running hours counter
- Engine temperature
- Oil pressure



### **WarningandShutdownAlarms**

- Low oil pressure
- High engine temperature
- Over speed
- Under speed
- Start failure
- Stop failure
- Emergency stop
- High/low battery voltage
- Aux. shutdown alarm
- Aux. Warning