

60Hz/1800 r.p.m-P.F.0.8					Prime Power	Standby Power	Rated Current
Genset	Engine	Alternator	Voltage (V)	PH	kW/kVA	kW/kVA	Amps
PGKT74	R4105ZLDS2	LSA 44.3 S5 UCI274C FPA22-689	240 (220-240)	1	64/80	72/90	333.3
		LSA44.3S3 UCI224F FPA22-587	380/220	3	68/85	74/92.5	121.6
		LSA44.3S3 UCI224F FPA22-546	208/120	3	64/80	72/90	222.1
		LSA44.3S2 UCI224F FPA22-546	220/127	3	64/80	72/90	210
		LSA44.3S2 UCI224F FPA22-546	230/132	3	64/80	72/90	200.8
		LSA44.3S2 UCI224F FPA22-546	480/277	3	64/80	72/90	96.2

Ratings:

All three Phase generator sets are rated at 0.8 power factor. All single-phase generator sets are rated at 0.8 or 1.0 power factor. POWERGEN reserves the right to change the design or specifications without notice and without any obligation or liability whatsoever.

Prime Power:

Available continuously at variable load in lieu of commercially purchased power for an unlimited number of hours per year in accordance with ISO8528-1, and an overload of 10% permitted for one hour in every twelve hours of operation in accordance with ISO 3046-1.

Standby Power:

Emergency Standby Power in variable load applications in accordance with ISO8528-1 in the event of a utility power failure. No overload available for this service as relevant alternators are peak continuous rated at 27°C.

Overall Dimensions (mm) & Weight (kg)

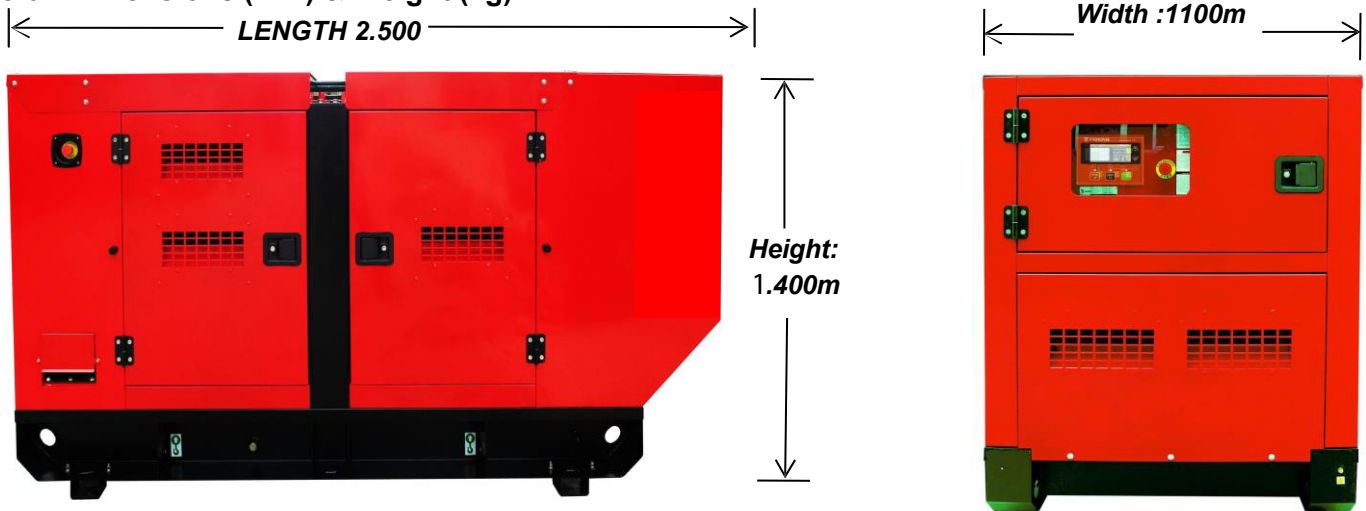

Weight (kg): 1650

Standard and Optional Accessories

System	Standard ●	Optional ○
Air Intake System	<ul style="list-style-type: none"> ● Standard air filter ● Air filter overload alarm 	<ul style="list-style-type: none"> ○ Air prefilter ○ Heavy air filter
Cooling System	<ul style="list-style-type: none"> ● 50°C radiator ● Low water level alarm ① ● Fan and belt guard ● Discharge valve 	<ul style="list-style-type: none"> ○ Antifreeze ○ Water jacket heater
Exhaust System	<ul style="list-style-type: none"> ● Stainless steel bellow ● Residential silencer ● Complete exhaust pipe ● Rain cap 	<ul style="list-style-type: none"> ○ Stainless steel silencer ○ Stainless steel exhaust pipe
Fuel System	<ul style="list-style-type: none"> ● 8 Hours integrated base fuel tank ● Standard fuel filter ● Fuel level gauge ● Fuel filling cap ● Fuel hose 	<ul style="list-style-type: none"> ○ 6 Hours double wall base fuel tank ○ Fuel-water separator ○ Oil level sensor ② ③ ○ Automatic fuel top up system ②
Lubrication System	<ul style="list-style-type: none"> ● Standard oil filter ● Manual oil pump and drain 	<ul style="list-style-type: none"> ○ Oil heater ○ Lube oil level indicator ○ Oil temperature indicator ②
Alternator and Electric Switch	<ul style="list-style-type: none"> ● Shunt or self excited ● Class H insulation ● H class temperature rise ● DELIXI MCCB ● Terminal connection lugs (L1, L2, L3, LN) 	<ul style="list-style-type: none"> ○ PMG or AREP (Leroy-Somer only) ○ Alternator space heaters ○ PT100 winding temperature sensors ○ Weaver AVR ○ Weaver prolapse transformer ○ F class temperature rise ○ 4 Pole circuit breaker with leakage protection ○ Circuit breaker - 4 pole ○ ABB MCCB ○ MCCB auxiliary contact and shunt tripping device
Control System	<ul style="list-style-type: none"> ● Comap Nano Plus for 4 cylinders engine ● Comap IntelliLite AMF20 for 6 cylinders or ECU engine 	<ul style="list-style-type: none"> ○ Panel lighting
Silent / Base	<ul style="list-style-type: none"> ● 67-72 db(A) @ 3 meters ● 4mm -6mm Steel base ● Transportation support leg ● Single hook ● Power coating enclosure ● Anti-vibration mounting between engine /alternator and baseframe ● Emergency stop mounted outside the canopy ● Standard color: Ral 3020 	<ul style="list-style-type: none"> ○ Forklift holes ○ Enclosure color: ○ Trailer for off road or on road
Start / Charge	<ul style="list-style-type: none"> ● Battery with bracket and cables ● Engine battery charger ● 3A Mains charger 	<ul style="list-style-type: none"> Low temperature starting batteries Battery switch High current charger (10A, 20A)

Remark:

- ① Not available for Perkins 400 series engines
- ② When you need the automatic oil top up system, you have to use the electrical oil level sensor.
- ③ You can choose either electrical oil level sensor or oil temperature sensor.

Engine

Engine specifications	
Manufacture	Kofo
Engine model	R4105ZLDS2
Engine type	4 cycle, in-line
Engine speed	1800 r.p.m
Prime power	75 kW
Standby power	82 kW
Governor type	Mechanical
Steady speed adjusting ratio at rated condition	≤5
Aspiration:	Turbocharged, air-to-air charge cooling
Displacement	3.76 L
Bore * Stroke	105 x125 mm
NO. of cylinders	4
Compression ratio	17.0:1
Engine idle speed	≤650 rpm
Fring order	1-3-4-2
Flywheel ring gear teeth number	130
Noise level @7m	72 dBA
Exhaust system	
Exhaust gas temperature	≤600°C
Exhaust outlet size	63 mm
Air intake system	
Maximum air intake restriction	
- Standard filter	≤1.20 kPa
- Air filter type	Dry

Fuel System	
Type injection system	Indirect Injection
Fuel consumption at 100% standby power	22.4 Litres/hour
Fuel consumption at 100% prime power	20.4 Litres/hour
Fuel consumption at 75% prime power	16.3 Litres/hour
Fuel consumption at 50% prime power	12.2 Litres/hour
Fuel consumption at 25% prime power	6.1 Litres/hour
Fuel tank capacity	8-12 hours
Lubrication System	
Oil sump capacity	15 Litres
Oil pressure	0.3-0.5 Mpa
Oil pressure at idle speed	≥0.1 Mpa
Lubricating method	Pressure lubrication
Oil consumption rate	1.63 g/kW.h
Max continuous oil temperature	105°C
Cooling system	
Total system capacity	16 Litres
Thermostat operation range	76-85 °C
Maximum top tank temperature	96°C
Electric System	
Starting method	Electric motor start
Electrical system voltage	24V
Battery	Maintenance-free
Connecting cables	Available

Alternator

General data	
Power factor	Cos φ = 0.8
Excitation	Shunt / Brushless

Insulation class	H
Bearing	Single
Altitude	≤ 1000 m

Ratings

Brand	Alternator	Number of wires	AVR Model	PH	Voltage (V)	Prime Power	Standby Power
						kW/kVA	kW/kVA
Leroy-Somer Stamford Tide	LSA 44.3 S5	4	R250	1	240 (220-240)	68/85	75/94
	UCI274C		AS440			67.2/84	N/A
	FPA22-689		SX460			64/80	70/87.5
Leroy-Somer Stamford Tide	LSA44.3S3	12	R250	3	380/220	63/79	70/87
	UCI224F		AS440			68/85	74/92
	FPA22-587		SX460			68/85	74/92
Leroy-Somer Stamford Tide	LSA44.3S3	12	R250	3	208/120	70/87	76/95
	UCI224F		AS440			67/83.8	73.5/91.9
	FPA22-546		SX460			64/80	71/87.5
Leroy-Somer Stamford Tide	LSA44.3S2	12	R250	3	220/127	64/80	70/87
	UCI224F		AS440			70/87.5	76/95
	FPA22-546		SX460			64/80	71/87.5
Leroy-Somer Stamford Tide	LSA44.3S2	12	R250	3	230/132	67/84	74/92
	UCI224F		AS440			70/87.5	76/95
	FPA22-546		SX460			64/80	71/87.5
Leroy-Somer Stamford Tide	LSA44.3S2	12	R250	3	480/277	70/88	77/96
	UCI224F		AS440			75/93.8	82/102.5
	FPA22-546		SX460			64/80	71/87.5

Control System



Comap Nano Plus

Comap IntelliLite AMF20

Comap IntelliLite AMF25

Viewable parameters	Phase voltage	3	3	3
	Wire voltage	3	3	3
	Current	Instrument	3	3
	Frequency	●	●	●
	Active power	×	●	●
	Reactive power	×	●	●
	Apparent power	×	●	●
	Power factor	×	●	●
	Electric energy metering	×	×	●
Generator protection	Abnormal voltage	●	●	●
	Over-current warning	×	●	●
	Over current protection	×	●	●
	Over Frequency protection	●	●	●
	Short circuit protection	MCCB	MCCB+○	MCCB+○
Engine figure	Oil pressure	●	●	●
	Water temperature	●	●	●
	Fuel level	○	○	○
	Speed	●	●	●
	Battery voltage	●	●	●
	Elapsed time	●	●	●
Engine protection	Low oil pressure warning	●	●	●
	Low oil pressure protection	●	●	●
	High temperature warning	●	●	●
	High temperature protection	●	●	●
	Overspeed warning	●	●	●
	Overspeed protection	●	●	●
	Charge fault	●	●	●
Function	Remote start-stop	●	●	●
	AMF	●	●	●
	Programmable input	3	7	7
	Programmable output	6	7	7
	Port extension	USB	○	○
	Remote monitoring	×	○	○
	Communication port	×	○	○
	CAN	●	○	●
	Start/Stop time control	×	×	●
	Maintenance tips	×	×	●
	Fault record	×	×	●
	Multi-language function	×	●	●

Remark: ● Standard

○ Optional

× NA

(Safety Installation: Detect - Control – Switch System)

POWERGEN offers not only a changeover switch but also an integrated mains detection and switch system for your 24 Hour Power Protection. The system enables automatic start-up and operation of the generating set in the event of a mains power failure, overvoltage or loss of phase; and also mains automatic re-transfer once it come back. The system has a wide application such as hospital, bank, telecom, airport, broadcasting station and hotels.

System Advantages

- Automatically transfer and re-transfer load from main power to gen-power without operator intervention operation. (Both automatic and manual)
- ATS Controller (AMF function), seamless integration with Intelligent 5.0
- Available from 32 – 3200A, better protection for 4 pole switch.
- Available in standard, bypass isolation and service-entrance configurations.
- Configurable in open, closed and programmed transition operating modes.
- Designed to interface seamlessly with POWERGEN generators and switchgear.
- Drip Proof IP23 Enclosure.
- Easy Installation: Wall-mounted & Floor standing
- Comes fully loaded with the technology to do the job.



Rated Current	Breaker Type			
	A	Chinese	ABB	Socomec
32	x		B	x
63	A		B	B
80	x		x	B
100	A		B	B
125	x		B	B
160	B		B	B
200	x		B	x
250	C		B	B
300	x		x	x
315	x		C	x
400	C		C	C
630	C		D	D
800	D		D	D
1000	D		D	D
1250	D		D	D
1600	D		D	E
2000	E		E	E
2500	E		E	E
3200	E		x	E

Dimensions : mm

A: 400x200x500

B: 500x300x650

C: 600x400x1200

D: 800x600x1400

E: 1000x800x1600